



臥式搪銑床

Horizontal Boring & Milling Machine

HBM-110 / HBM-110L



Founded in Taiwan in 1988, Fortworth, also known as Chung Sing Machinery Co., Ltd., is a leading manufacturer of high-precision boring and milling machines, and CNC horizontal boring machines.

Fortworth focuses on developing state-of-the-art mechanical engineering by continuously innovating our own unique products to fulfill the ever-changing needs of our customers.



昌鑫機械工業股份有限公司
CHUNG SING MACHINERY CO., LTD.

429台灣 台中市神岡區豐工三路1號

NO.1, FENGGONG 3RD RD., SHENGANG DIST.,
TAICHUNG CITY 429, TAIWAN

TEL: 886-4-25252723

FAX: 886-4-25270957

E-mail: csmill@ms27.hinet.net

<http://www.chungsing.com>

臥式搪銑床

HBM-110

Horizontal Boring & Milling Machine



主軸 MAIN SPINDLE (ISO50)

- 主軸配用斜角滾柱高精密軸承，剛性佳適合重切削。
 - 主軸外徑110mm，行程(Z軸)400mm，全齒式強力型齒輪二段變速傳動，配有循環油潤滑噪音低壽命長。
 - 強力型主軸馬達15kW，二段變速傳動最高轉速1000rpm，扭力輸出大，加工適用範圍廣。
 - 附氣壓動力刀具鎖緊及鬆脫裝置，上下刀具快速簡便。
-
- Working spindle quill is mounted on high precision tapered roller bearing, available for heavy duty machining.
 - Working spindle diameter is 110mm, with 2-steps geared box for the speed ranges variable.
 - Working spindle stroke (Z-axis travel) is 400mm.
 - With powerful spindle motor 20HP.
 - With air power draw bar for tool clamping / unclamping.

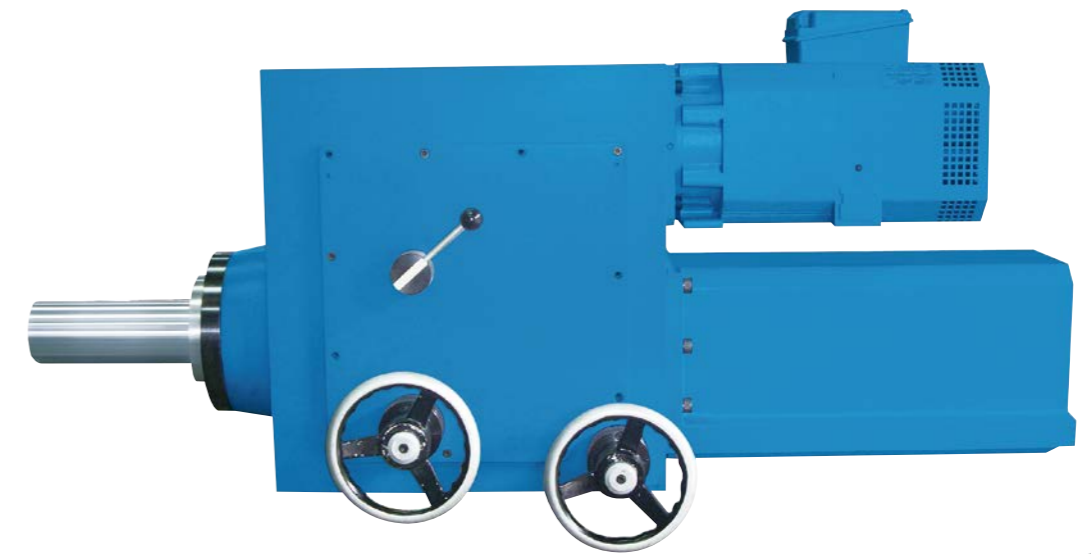

臥式搪銑床

HBM-110L

Horizontal Boring & Milling Machine

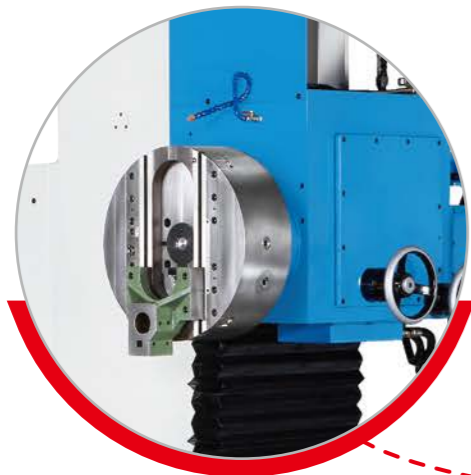

展刀頭(選配)
Facing Head (Option)

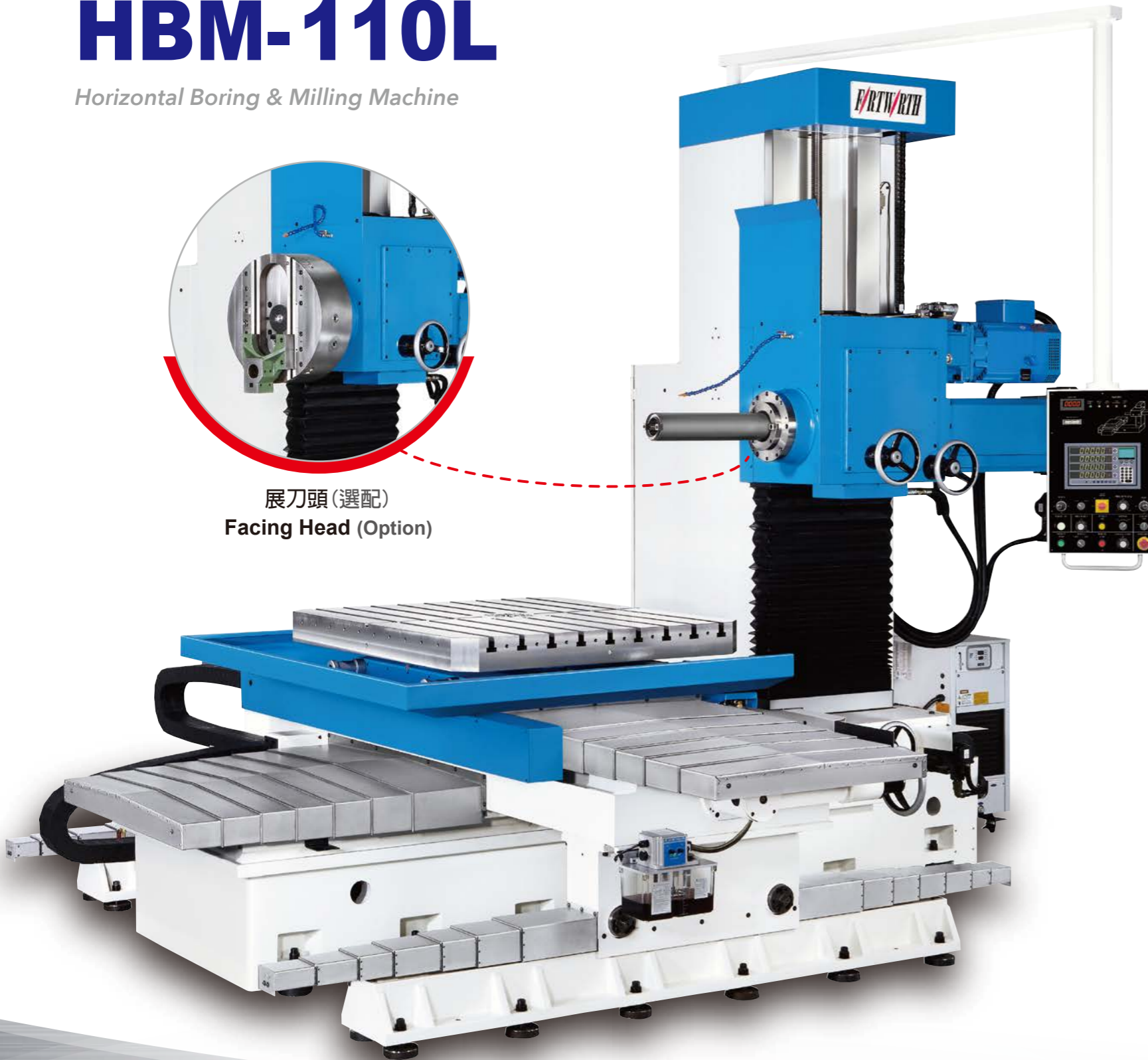

主軸 MAIN SPINDLE (ISO50)

- 主軸配用斜角滾珠高精密軸承。
- 主軸外徑110mm，行程(Z軸)550mm，配有循環油潤滑噪音低壽命長，搭配二段式減速機，加大扭力，適合重切削。
- 強力型主軸馬達15kW，二段變速傳動最高轉速1500rpm，扭力輸出大，加工適用範圍廣。
- 附氣壓動力刀具鎖緊及鬆脫裝置，上下刀具快速簡便。
- Working spindle quill is mounted on high precision angular contact ball bearing, available for heavy duty machining.
- Working spindle diameter is 110mm, with 2-steps geared box for the speed ranges variable.
- Working spindle stroke (Z-axis travel) is 550mm.
- With powerful spindle motor 20HP.
- With air power draw bar for tool clamping / unclamping.

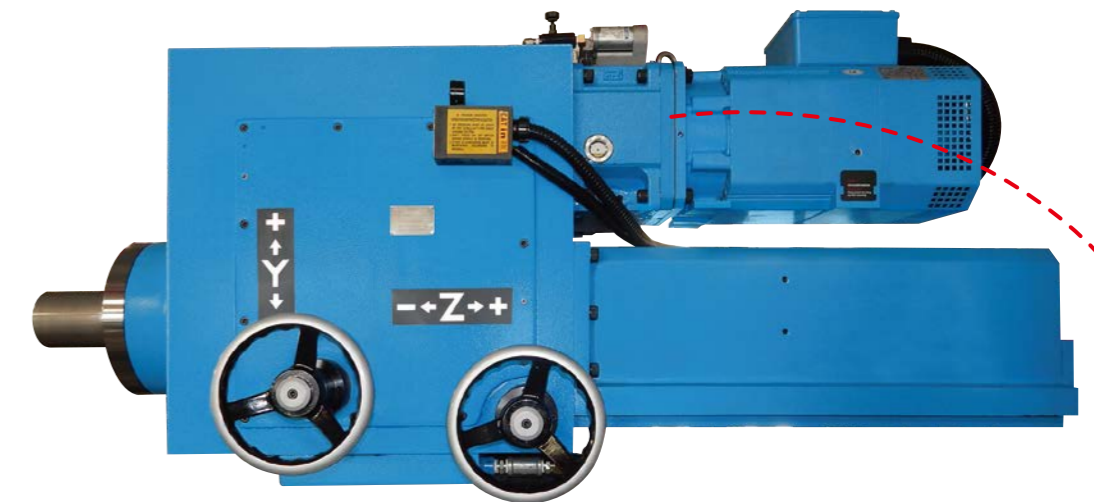

主軸高-低檔變速齒輪箱 Gearbox for spindle high-low speed change

- 廣泛加工範圍：寬廣的速度範圍增加加工靈活性，且可保有加工精度。
- 增加加工扭矩：低速檔增加扭矩適合重切削加工。
- 加工材料範圍：可加工材料適範圍大，硬質材料用低速和高扭矩，軟材料用高速檔。
- Wide machining range: wide speed increases flexibility but has no influence on precision.
- Increased machining torque: increased torque via reduction ratio.
- Wide material range: low speed and high torque for hard material, and high speed for soft material.

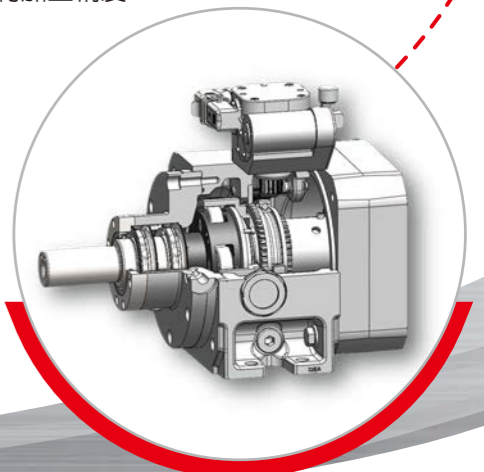

工作台 WORKING TABLE

- 空氣浮動高精度分度工作台可360度旋轉，最小分割角度1度。
- 工作台最大荷重達2500kg(HBM-110)/5000kg(HBM-110L)。
- 工作台有氣壓鎖緊裝置。
- Build-in index table 1000x800mm (HBM-110) / 1200x1400mm (HBM-110L), minimum indexing 1 degree, full 360 degree.
- Table load capacity maximum 2500kg (HBM-110) / 5000kg (HBM-110L).
- Table with pneumatic clamping system.



機械結構 MACHINE STRUCTURE

- 機身及底座採用箱型結構及加強肋設計，整體構造堅強、穩重，適合重切削。
- 機體主要結構均採用高級強韌鑄鐵鑄造，經退火處理，確保材質穩定。
- 三軸滑軌皆經硬化處理，精密研磨，機械精度壽命長。
- X及W軸滑軌面裝設有防屑伸縮鈹金，確保精密滑道壽命。
- 三軸採用油壓鎖緊裝置。
- XZ及W軸配用鋼珠螺桿，進給平穩快速。
- 主軸頭附平衡配重，使頭部移動平順確保精度穩定。
- Rigid box-type column and base features outstanding stability in heavy duty machining.
- All casting are made of high quality cast iron and are stress relieved.
- Hardened and precision grounded box way construction for X,Y and W-axis.
- Telescopic covers for the cross and longitudinal traverses.
- X,Z and W-axis with ballscrew.
- Spindle headstock balance is accurately taken and a counter weight permits the head to travel smoothly and to retain its accuracy stability.



主軸端 SPINDLE NOSE (BT50, NT50, CAT50 are available)

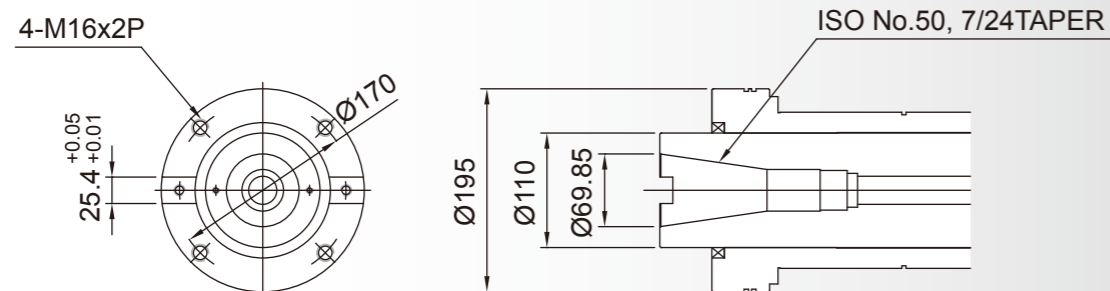

選配 OPTIONS

主軸延伸襯套
Spindle extension sleeve
90度銑頭
Right angle milling head
萬向銑頭
Universal milling head
展刀頭
Facing head
O.D. 560mm
主軸油冷卻裝置
Spindle Oil Cooler
(For HBM-110)

工作台規格 Table and T-slot size

HBM-110

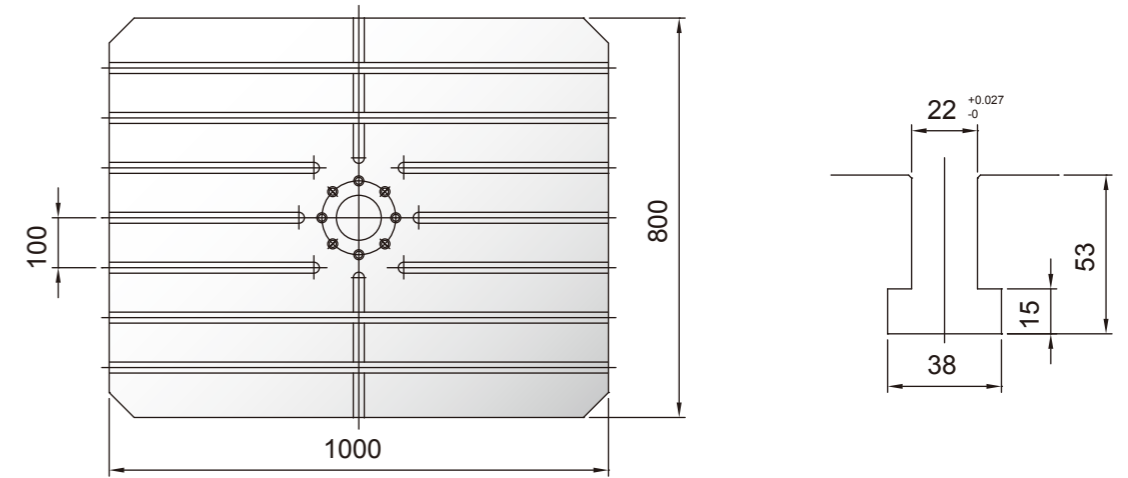

操控面板 OPERATOR'S CONTROL PANEL

整合式操控面板將各種操控功能集中，提供使用者更便利、更有效率的操控介面。
All functions are integrated operator's control panel enhance operation efficiency.



A version
(For other brands of DRO)



B version
(For DRO brand: NEWALL & FAGOR)
For the B version control panel,
the W and Z axis will be reversed.
Z = Spindle travel, W = Saddle travel

HBM-110L

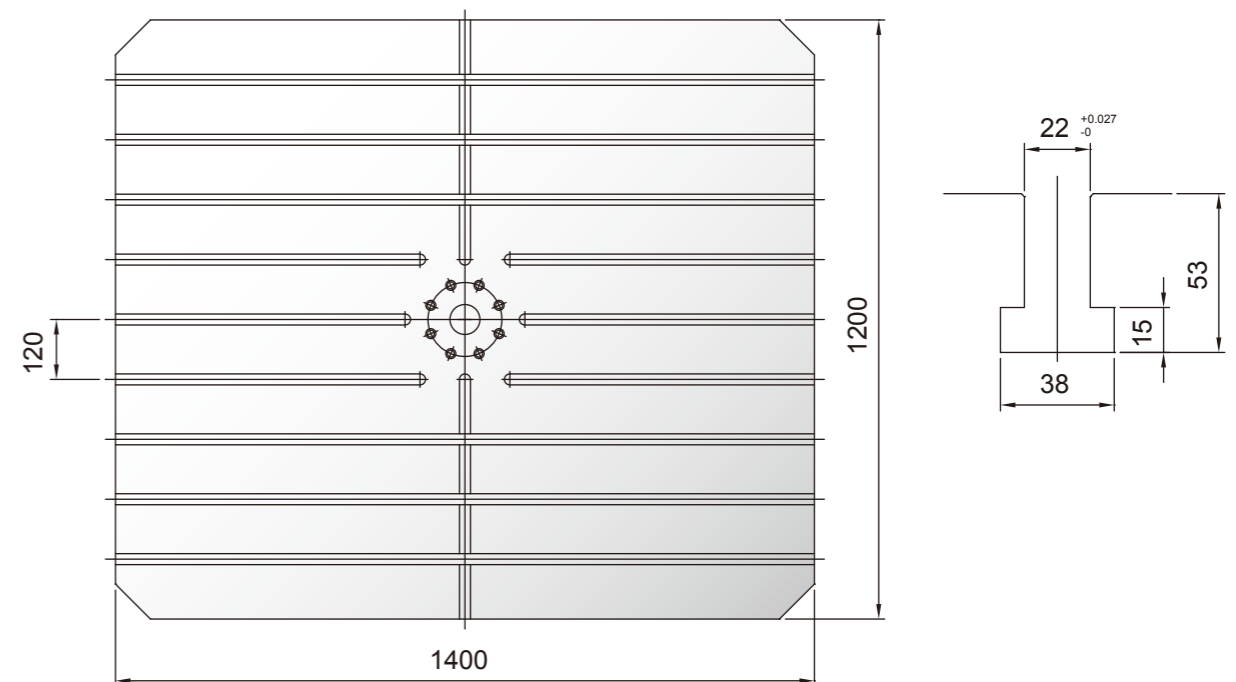

外觀尺寸 EXTERNAL DIMENSIONS

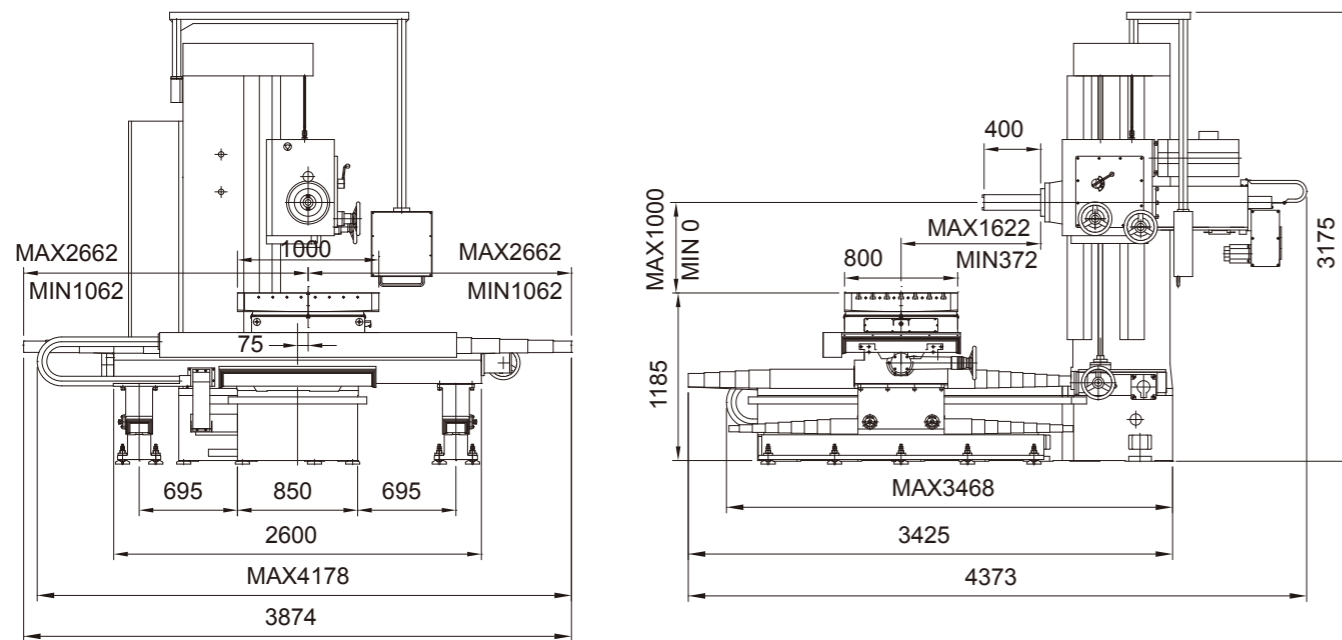
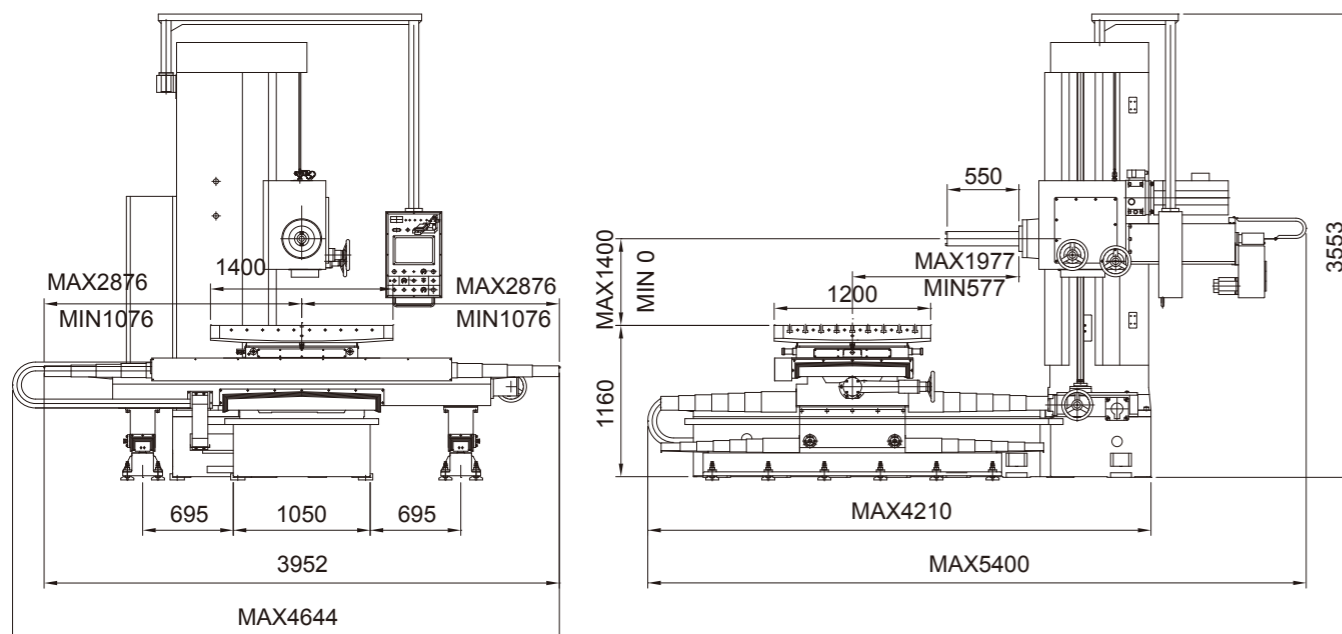
HBM-110

HBM-110L

規格表 SPECIFICATIONS

型號 MODEL		HBM-110		HBM-110L	
工作台 Working Table		unit			
工作台尺寸	Working table size	mm	1000x800		1400x1200
分割角度	Table indexing (360 degree)	deg	1 degree/division		1 degree/division
T型槽	T-Slot (width x no. x pitch)	mm	22H8x7x100		22H8x9x120
最大負載	Max. load capacity	kg	2500		5000
容量 Capacity					
X軸行程	X axis (Table longitudinal)	mm	1600		1800
Y軸行程	Y axis (Spindle vertical)	mm	1000		1400
W軸行程	W axis (Table cross)	mm	1250		1400
Z軸行程	Z axis (Spindle axial)	mm	400		550
主軸中心至工作台面距離	Spindle center to table top	mm	0~1000		0~1400
主軸鼻端至工作台中心距離	Spindle end to table center	mm	372~1622		577~1977
主軸 Main Spindle					
主軸鼻端	Spindle nose	mm	ISO R297 No.50		ISO R297 No.50
主軸外徑	Spindle diameter	mm	110		110
轉速/齒輪二段轉換	Spindle speed (2 ranges, variable)	rpm	20~1000		20~1500
進給速率 Feed / Rapid					
X,Y,W 軸快速移動速率	X,Y,W rapid	mm/min	2800		2800
Z 軸快速移動速率	Z rapid	mm/min	1200		1200
X,Y,W 軸進給速率	X,Y,W feed	mm/min	3~950		3~950
Z 軸進給速率	Z feed	mm/min	3~400		3~400
進給段數	Change of feeds	-	無段Infinitely variable		無段Infinitely variable
馬達 Motors					
主軸馬達	Spindle motor	kW	AC15		AC15
X/Y/W 軸伺服馬達	Feed motor for X,Y,Z axis (Servo)	kW	2.9		2.9
Z 軸伺服馬達	Feed motor for W axis (Servo)	kW	1.3		1.3
主軸頭循環潤滑馬達	Lube pump for headstock	kW	AC0.2-4P		-
油冷機	Oil cooler	W	-		678
軌道自動潤滑馬達	Lube pump for slideway	W	AC3.5-2P		AC3.5-2P
切削冷卻液裝置	Coolant pump	-	AC1/6HP (0.12kW-2P)		AC1/6HP (0.12kW-2P)
油壓馬達	Hydraulic pump for axis clamp	-	AC2HP (1.5kW-4P)		AC2HP (1.5kW-4P)
機械一般規格 Machine Size					
佔地面積	Floor area	mm	3874 x 4373		4644 x 5400
機械重量(約)	Machine weight (Approx.)	kg	12500		16000
機械標準色	Standard color	-	Blue & White (藍&白)		Blue & White (藍&白)

■ 本公司保留產品規格、外觀及配備等變更之權利。 Designs and specifications are subject to change without prior notice.

標準附件 STANDARD ACCESSORIES

- 自動潤滑裝置 Automatic lubrication system
- 切削冷卻液裝置 Coolant system
- 氣動鎖刀裝置 Air power draw-bar
- X, Z及W軸配用滾珠螺桿 X, Z & W-axis with ballscrew
- 主軸正反轉攻牙功能 Tapping function
- X, Y及W軸油壓鎖定裝置 X, Y & W-axis with hydraulic clamp
- 工具箱及調整工具 Tool box with adjustment tools
- 水平調整螺絲及墊塊 Leveling blocks and bolts

選配附件 OPTIONS ACCESSORIES

- 90度銑頭 Right angle milling head
- 萬向銑頭 Universal milling head
- 主軸延伸襯套 Spindle extension sleeve
- 光學尺數顯 Digital read out
- 變壓器 Transformer for other than 220/3/60
- 展刀頭 Facing head
- 主軸油冷卻裝置 Spindle Oil Cooler (For HBM-110)